

# UN1300D1 Specifications

## FEATURES

- European, oil-cooled, two-headed motor-driven servo drive delivers fast response and maximise energy efficiency
- Austrian KEBA control with dual CPU is stable, fast & accurate with 12" TFT colour touch screen display
- Based on European design technology
- High rigidity clamping unit delivers stability & accuracy, combined with uniform stress distribution on the tie bars
- Rexroth highly responsive dual proportional valves on clamping unit offers accurate repeatability
- L-shape guide rails deliver platen movement accuracy up to 0.05mm
- Mould open position accurate to  $\pm 0.2\text{mm}$
- Tie bars independent of moving platen offers precision & speed
- Dry cycle times faster than toggle lock machines
- Small footprint compared to traditional three platen design
- Low pressure & highly sensitive mould protection
- Integrated linear guide rails on injection unit offer low resistance and accuracy
- Repeatability of part weight  $\leq 3\%$
- Durable ceramic heater bands
- Time, position or pressure switchover for holding phase start
- Ultrasonic displacement sensor
- Central lubrication for injection unit
- European oil seals & guide rings
- Double core pull
- Double air blast circuit
- Euromap robot interface & Euromap mounting
- Hydraulic ejector
- T-Slot platen
- Auto mould height adjustment
- Oil pre-heating
- IP54 electrical enclosure
- Precise filtration and independent cooling system
- Service, warranty & parts supported by our in-house engineers



INJECTION UNIT		6800				9000				10900				14500		
		A	B	C	D	A	B	C	D	A	B	C	D	A	B	C
Screw diameter	mm	92	100	108	116	100	108	116	125	108	116	125	135	125	135	145
Shot volume	cm <sup>3</sup>	3191	3770	4397	5073	4320	5038	5813	6748	5222	6024	6995	8159	7977	9304	10733
Shot weight	g	2936	3468	4045	4667	3974	4636	5348	6208	4804	5542	6435	7506	7339	8560	9875
Injection pressure	bar	2130	1800	1540	1340	2090	1790	1550	1340	2100	1820	1570	1350	1810	1560	1350
Screw L:D ratio		21.7	22	21.5	20	21.6	20	21.6	20	23.7	22	21.6	20	23.6	22	20
Injection rate	cm <sup>3</sup> /s	615	726	847	980	766	894	1031	1197	815	940	1092	1273	1316	1536	1772
Max. injection speed	mm/s	92.5				97.6				89				107		
Screw stroke	mm	480				550				570				650		
Max. screw speed	r/min	145				128				112				120		
Barrel heating zone no.	PCS	7				7				8				8		

CLAMPING UNIT		
Clamping force	kN	13000
Opening force	kN	875
Platen size	mm	1975 x 1875
Distance between tie-bars	mm	1390 x 1280
Mould thickness (min-max)	mm	650 - 1350
Opening stroke	mm	2200 / 1500
Max. daylight	mm	2850
Ejector force	kN	274
Ejector stroke	mm	360
Ejector number	PCS	25

ELECTRICAL & HYDRAULIC UNITS																
System pressure	MPa	17.5 / 30				17.5 / 30				17.5 / 30				17.5 / 30		
Pump motor	kW	89 + 7.5				110 + 7.5				89 + 37 + 7.5				89 + 66 + 11		
Total power	kW	143.5	143.5	153.1	153.1	169.3	169.3	178.4	178.4	199.9	199.9	204.1	204.1	253.7		
Heater power	kW	47	47	56.6	56.6	51.76	51.76	60.9	60.9	66.37	66.37	70.63	70.63	87.7		

GENERAL																
Oil tank capacity	L	1150				1400				1600				2100		
Machine dimensions (LxWxH)	m	10.8 x 3.5 x 3.1				10.9 x 3.5 x 3.2				11.4 x 3.5 x 3.2				11.7 x 3.5 x 3.5		
Machine weight	T	36 + 8.5				36 + 11				36 + 13				36 + 16.5		
Max. mould weight	T	23				23				23				23		

## MACHINE DIMENSIONS

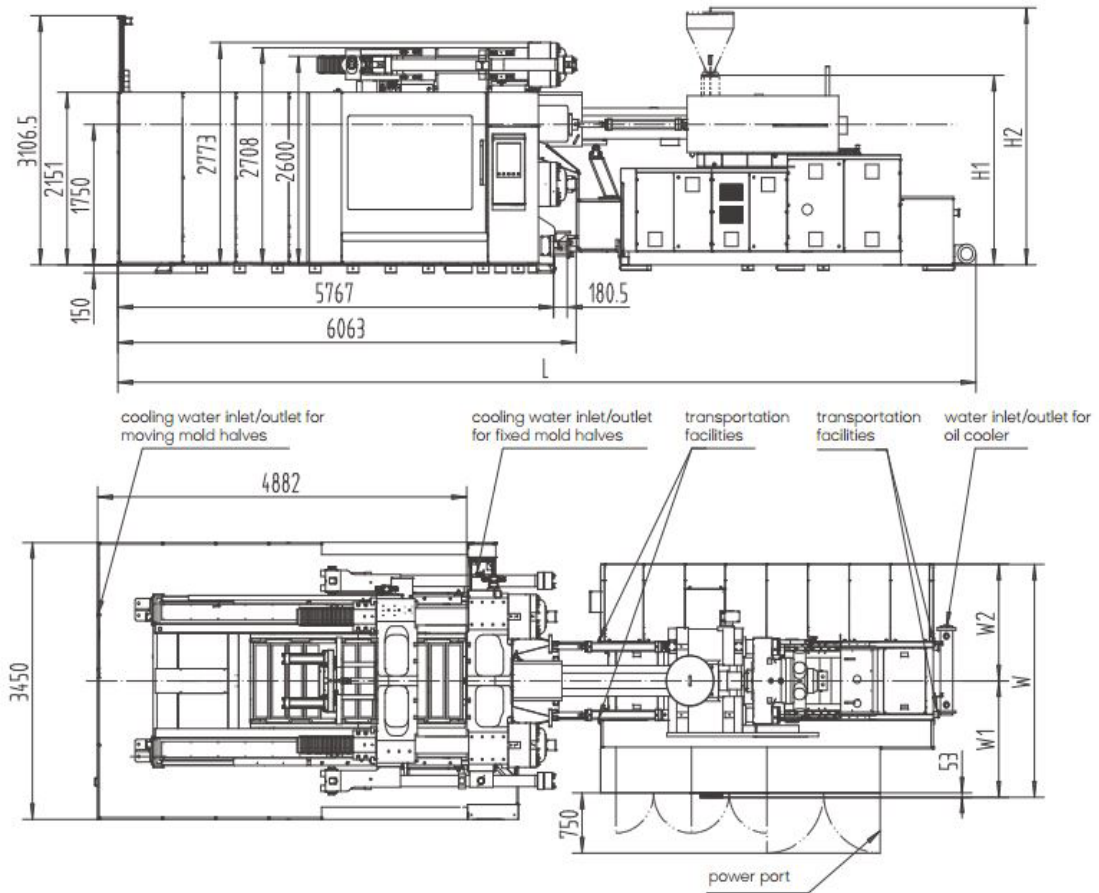

## PLATEN DRAWINGS

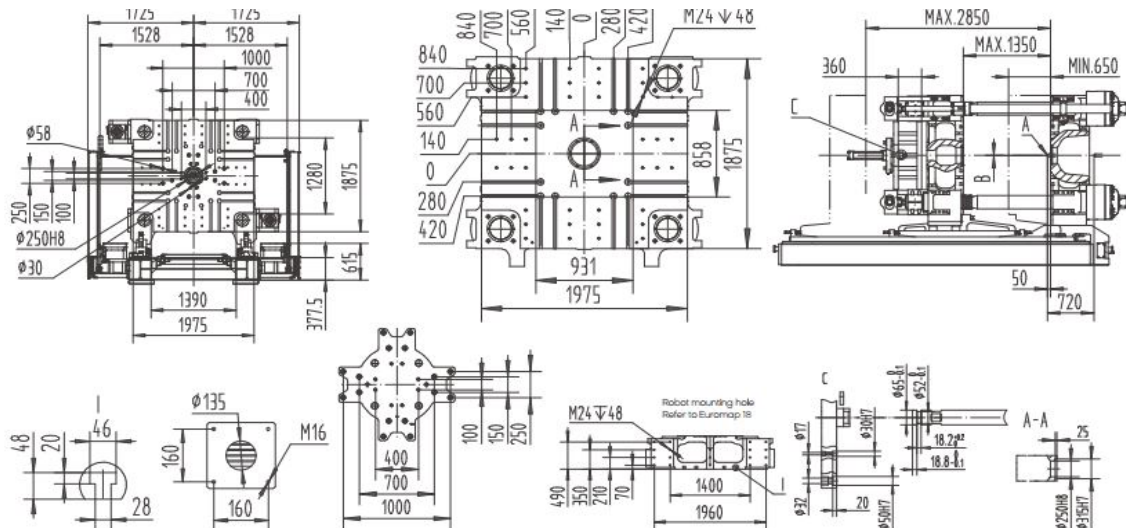

Model	A	B	L	H1	H2	W	W1	W2	Main power cord size	Full-load current	Bearing capacity of foundation	Mold cooling water ports	Cooling water flow (mold excluded)	Cooling water pressure	Compressed air pressure
	mm	mm	mm	mm	mm	mm	mm	mm	mm <sup>2</sup>	A	t/m <sup>2</sup>	n×L/min	L/min	bar	bar
UN1300D1-IU6800	SR15	Φ4.5	10756	1935	2800	2711	1352	1359	95	259.84	8	(8+8)×11	100	3~4	5~6
UN1300D1-IU9000	SR15	Φ4.5	10886	2319	3161	2906	1450	51455.5	95	316.71	8	(8+8)×11	100	3~4	5~6
UN1300D1-IU10900	SR20	Φ6	11356	2354	3196	2906	1450	51455.5	120	370.88	8	(8+8)×11	100	3~4	5~6
UN1300D1-IU14500	SR20	Φ8	11681	2473	3460	3146	1548	1598	150	470.42	8	(8+8)×11	250	3~4	5~6